

1. Scope

- 1.1 This datasheet is the characteristics of High Power Thick Film Chip Resistors manufactured by KOME
- 1.2 High power standard size
- 1.3 Suitable for both wave & re-flow soldering
- 1.4 AEC-Q200 qualified
- 1.5 Application: AV adapters, LCD back-light, camera strobe ect.
- 1.6 Compliant with RoHS directive.
- 1.7 Halogen free requirement.

2. Part Number

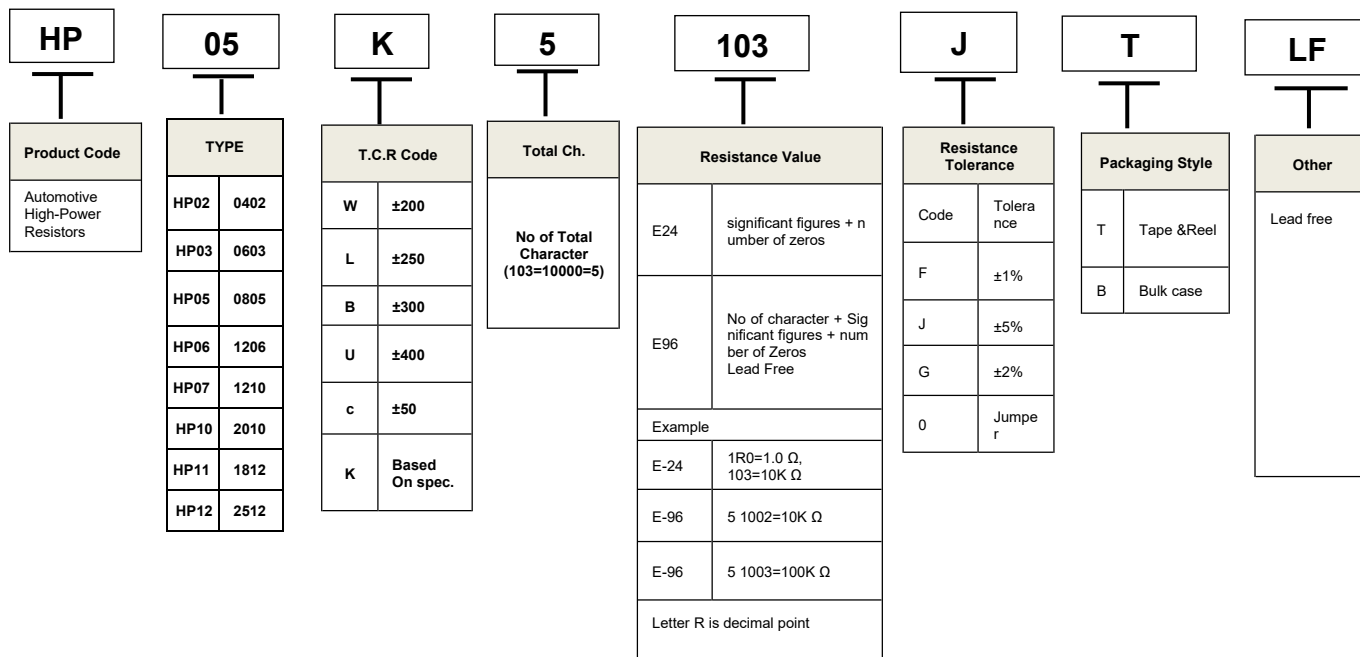

3. Marking

3.1 For HP02 size. Due to the very small size of the resistor's body, there is no marking on the body.



3.2 Normally, the marking of 0Ω HP03, 0Ω HP05, 0Ω HP06, 0Ω HP07, 0Ω HP10, 0Ω HP11, 0Ω HP12 resistors as following



0 → 0Ω

3.3 ±5% tolerance products (E-24 series):

3 codes.

1st~2nd codes are the significant figures of resistance value,

and the rest code is the power of ten.



333 → 33KΩ

3.4 ±0.5%, ±1% tolerance products (E-96 series):

4 codes.

1st~3rd codes are the significant figures of resistance value,

and the rest code is the power of ten.

Letter "R" in mark means decimal point.



2701 → 2.7KΩ

3.5 More than HP05 specifications (including) 4 digits,

Product below 1Ω, show as following, the first digit

Is "R" which as decimal point.



R300 → 0.3Ω

3.6 Standard E-96 series values of HP03 ≤±1% : due to the small size of the resistor's body, 3 digits marking will be used to indicate the accurate resistance value by using the following multiplier & resistance code.

Multiplier Code (for HP03 ≤±1% marking)

Code	A	B	C	D	E	F	G	H	X	Y	Z
Multiplier	10 ⁰	10 ¹	10 ²	10 ³	10 ⁴	10 ⁵	10 ⁶	10 ⁷	10 ⁻¹	10 ⁻²	10 ⁻³

Standard E-96 series Resistance Value code (for HP03 ≤±1% marking)

Value	Code	Value	Code	Value	Code	Value	Code
100	01	178	25	316	49	562	73
102	02	182	26	324	50	576	74
105	03	187	27	332	51	590	75
107	04	191	28	340	52	604	76
110	05	196	29	348	53	619	77
113	06	200	30	357	54	634	78
115	07	205	31	365	55	649	79
118	08	210	32	374	56	665	80
121	09	215	33	383	57	681	81
124	10	221	34	392	58	698	82
127	11	226	35	402	59	715	83
130	12	232	36	412	60	732	84
133	13	237	37	422	61	750	85
137	14	243	38	432	62	768	86
140	15	249	39	442	63	787	87
143	16	255	40	453	64	806	88
147	17	261	41	464	65	825	89
150	18	267	42	475	66	845	90
154	19	274	43	487	67	866	91
158	20	280	44	499	68	887	92
162	21	287	45	511	69	909	93
165	22	294	46	523	70	931	94
169	23	301	47	536	71	953	95
174	24	309	48	549	72	976	96

So the resistance value are marked as the following examples



$$1.96K\Omega = 196 \times 10^1 \Omega = 29B$$



$$12.4\Omega = 124 \times 10^{-1} \Omega = 10X$$

3.7 Standard E-24 and not belong to E-96 series values ($\leq \pm 1\%$) of 0603 size: the marking is the same as 5% tolerance but marking as underline.



$$\underline{333} = 33K\Omega$$



$$\underline{680} = 68\Omega$$

4. Dimension

Type	Dimension(mm)				
	L	W	H	A	B
HP02(0402)	1.00±0.10	0.50±0.05	0.35±0.05	0.20±0.10	0.25±0.10
HP03(0603)	1.60±0.10	0.80±0.10	0.45±0.10	0.30±0.20	0.30±0.20
HP05(0805)	2.00±0.15	1.25+0.15/-0.10	0.55±0.10	0.40±0.20	0.40±0.20
HP06(1206)	3.10±0.15	1.55+0.15/-0.10	0.55±0.10	0.45±0.20	0.45±0.20
HP07(1210)	3.10±0.10	2.50±0.15	0.55±0.10	0.50±0.25	0.50±0.20
HP10(2010)	5.00±0.10	2.50±0.20	0.55±0.10	0.60±0.25	0.50±0.20
HP11(1812)	4.50±0.20	3.20±0.20	0.55±0.20	0.50±0.20	0.50±0.20
HP12(2512)	6.35±0.10	3.20±0.20	0.55±0.10	0.60±0.25	0.50±0.20

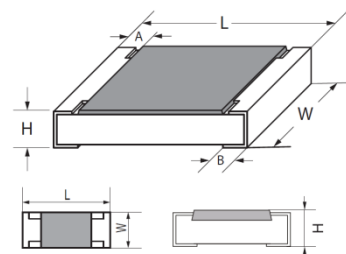

5. Resistance Range

Type	Size	Power Rating	Resistance Range of 0.5%, 1%, 5%	Max. Working Voltage/Current	Max. Overload Voltage/ Current	Dielectric withstanding Voltage	Operating Temperature
HP02	0402	1/10W	1Ω~10M 0Ω: ≤10mΩ	50V 3A	100V 6A	100V	-55℃~155℃
HP03	0603	1/5W	0.1Ω~10M 0Ω: ≤8mΩ	75V 5A	150V 10A	300V	-55℃~155℃
HP05	0805	1/3W	0.01Ω~10M 0Ω: ≤5mΩ	150V 6A	300V 12A	500V	-55℃~155℃
HP06	1206	1/2W	0.01Ω~10M 0Ω: ≤5mΩ	200V 10A	400V 20A	500V	-55℃~155℃
HP07	1210	3/4W	0.1Ω~10M 0Ω: ≤4mΩ	200V 12A	500V 24A	500V	-55℃~155℃
HP10	2010	1W	0.01Ω~10M 0Ω: ≤5mΩ	200V 12A	500V 24A	500V	-55℃~155℃
HP11	1812	1.25W	0.1Ω~10M 0Ω: ≤5mΩ	200V 12A	500V 24A	500V	-55℃~155℃
HP12	2512	2W	0.01Ω~10M 0Ω: ≤5mΩ	300V 16A	500V 32A	500V	-55℃~155℃

6. Soldering pad size recommended

Type	Dimension(mm)			
	A	B	C	D
HP02	0.5±0.05	0.5±0.05	0.6±0.05	1.5±0.05
HP03	0.8±0.05	0.8±0.05	0.9±0.05	2.4±0.05
HP05	1.0±0.1	1±0.1	1.4±0.1	3±0.1
HP06	2.0±0.1	1.1±0.1	1.8±0.1	4.2±0.1
HP07	2.0±0.1	1.1±0.1	2.9±0.1	4.2±0.1
HP10	3.6±0.1	1.4±0.1	3±0.1	6.4±0.1
HP11	3.0±0.1	1.4±0.1	3.7±0.1	5.8±0.1
HP12	4.9±0.1	1.35±0.1	3.7±0.1	7.6±0.1

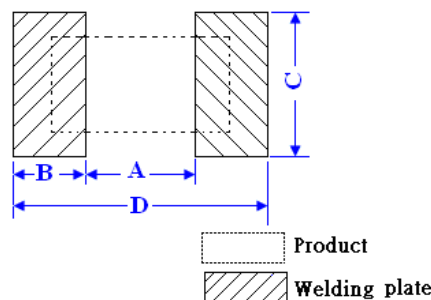

7. Derating

Power rating will change based on continuous load at ambient temperature from -55. It is constant between -55 to 70°C, and derate to zero when temperature rise from 70 Voltage

Resistors shall have a rated direct-current (DC) continuous working voltage or an approximate root-mean-square (RMS) alternating-current (AC) continuous working voltage at com frequency and waveform corresponding to the power rating, as determined from the followin

$$RCWV = \sqrt{P} \times R$$

Remark: RCWV: Rating Continuous Working Voltage (Volt.) P: power rating (Watt) R: nominal resistance (Ω) In no case shall the rated DC or RMS AC continuous working voltage be greater than the applicable maximum value. The overload voltage is 2.5 times RCWV or Max. Overload voltage whichever is lower.

Curve

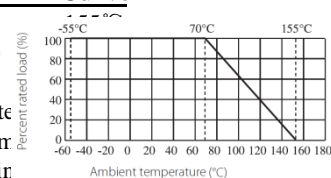

8. Structure

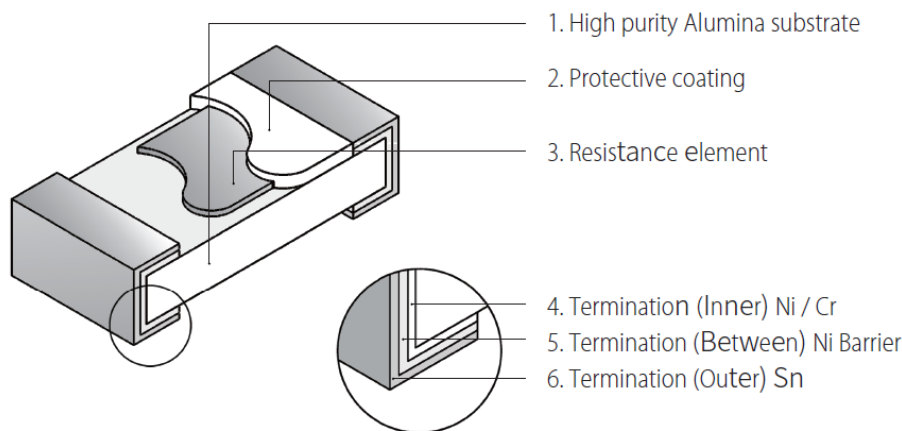

9. Performance Specification

Characteristic	Limits	Ref. Standards	Test Methods
Operational life	$\pm 0.5\%, \pm 1\%: \pm(1.0\%+0.1\Omega)$ $\pm 5\%: \pm(3.0\%+0.1\Omega)$	MIL-STD-202 Method 108	125°C, at 36% of operating power, 1000H(1.5 hours "ON", 0.5 hour "OFF"). Measurement at 24±4 hours after test conclusion.
	HP02: <20mΩ; HP03 <16 mΩ; HP05、HP06、HP10、HP11、HP12: <10 mΩ HP07: <8mΩ		Apply to rate current for 0 Ω
Electrical Characterization (T.C.R)	HP02: 1Ω<R≤10Ω: ±400 PPM/°C 10Ω<R≤100Ω: ±200 PPM/°C 100Ω<R≤10M: ±100 PPM/°C HP03: 0.1Ω<R<0.2Ω: ±200PPM/°C 0.2Ω≤R≤10M: ±100 PPM/°C HP05: 10mΩ≤R≤15mΩ: ±800ppm/°C 15mΩ<R≤25mΩ: ±600ppm/°C 25mΩ<R≤50mΩ: ±400ppm/°C 50mΩ<R<0.1Ω: ±200ppm/°C 0.1Ω≤R≤10M: ±100ppm/°C HP06: 10mΩ≤R<15mΩ: ±700 ppm/°C 15mΩ≤R<30mΩ: ±400 ppm/°C 30mΩ≤R<50mΩ: ±300 ppm/°C 50mΩ≤R<0.1Ω: ±150 ppm/°C 0.1Ω≤R≤10M: ±100 ppm/°C HP10: 10mΩ≤R<15mΩ: 0~+800 ppm/°C 15mΩ≤R<50mΩ: 0~+600 ppm/°C 50mΩ≤R<10M: ±100 ppm/°C HP07、HP11: ±100PPM/°C HP12: 10mΩ≤R<20mΩ: 0~+800ppm/°C 20mΩ≤R≤50mΩ: 0~+400ppm/°C 50mΩ<R≤10M: ±100ppm/°C	GB/T 5729 4.8 JIS-C-5201 4.8 IEC 60115-1 6.2	Natural resistance changes per temp. Degree centigrade $\frac{R_2 - R_1}{R_1(t_2 - t_1)} \times 10^6 \text{ (PPM/°C)}$ R ₁ : Resistance Value at room temperature (t ₁) ; R ₂ : Resistance at test temperature (t ₂) t ₁ : +25°C or specified room temperature t ₂ : Test temperature (-55°C or 125°C)
Short-time overload	$\pm 0.5\%, \pm 1\%: \pm(1.0\%+0.1\Omega)$ $\pm 5\%: \pm(2.0\%+0.1\Omega)$	GB/T 5729 4.13 JIS-C-5201 4.13 IEC 60115-1 8.1.4.2	Permanent resistance change after the application of a potential of 2.5 times RCWV or Max. Overload Voltage whichever less for 5 seconds..
	HP02: ≤10mΩ; HP03 ≤8 mΩ; HP05、HP06、HP10、HP11、HP12: ≤5mΩ HP07: ≤4mΩ		Apply max Overload current for 0Ω
External Visual	Marking Complete , no mechanical damage	MIL-STD-883 Method 2009	Electrical test not required. Inspect device construction, marking and workmanship
Physical Dimension	Reference 5 Dimension Standards	JESD22 MH Method JB-100	Verify physical dimensions to the applicable device detail specification. Note: User(s) and Suppliers spec. Electrical test not required.
Resistance to Solvent	Marking Complete , no mechanical damage	MIL-STD-202 Method 215	Note: Add Aqueous wash chemical – OKEM Clean or equivalent. Do not use banned solvents.
Terminal Strength	Not broken	AEC-Q200-006	HP02: 5N; others: 17.7N, 60±1 seconds.
High Temperature Exposure (Storage)	$\pm 0.5\%, \pm 1\%: \pm(1.0\%+0.1\Omega)$ $\pm 5\%: \pm(3.0\%+0.1\Omega)$	MIL-STD-202 Method 108	1000hrs. @T=155°C. Unpowered. Measurement at 24±4 hours after test conclusion.
	HP02: ≤10mΩ; HP03 ≤8 mΩ; HP05、HP06、HP10、HP11、HP12: ≤5mΩ HP07: ≤4mΩ		

Temperature Cycling	$\pm(1.0\%+0.05\Omega)$	JESD22 Method JA-104	1000 Cycles (-55°C to +155°C). Measurement at 24±4 hours after test conclusion.
	HP02: ≤10mΩ;HP03≤8 mΩ; HP05、HP06、HP10、HP11、HP12: ≤5mΩ HP07: ≤4mΩ		
Biased Humidity	$\pm 0.5\%, \pm 1\%: \pm(1.0\%+0.05\Omega)$ $\pm 5\%: \pm(3.0\%+0.05\Omega)$	MIL-STD-202 Method 103	1000 hours 85°C,85%RH. Note: Specified conditions: 10% of operating power. Measurement at 24±4 hours after test conclusion.
	HP02: ≤10mΩ;HP03≤8 mΩ; HP05、HP06、HP10、HP11、HP12: ≤5mΩ HP07: ≤4mΩ		Apply to rate current for 0 Ω
Mechanical Shock	$\pm 0.5\%, \pm 1\%: \pm(1.0\%+0.1\Omega)$ $\pm 5\%: \pm(2.0\%+0.1\Omega)$	MIL-STD-202 Method 213	Half sine wave, acceleration 100g's, each three times in X, Y and Z directions, pulse width 6ms.
	HP02: ≤10mΩ;HP03≤8 mΩ; HP05、HP06、HP10、HP11、HP12: ≤5mΩ HP07: ≤4mΩ		
Vibration	$\pm 0.5\%, \pm 1\%: \pm(1.0\%+0.1\Omega)$ $\pm 5\%: \pm(2.0\%+0.1\Omega)$	MIL-STD-202 Method 204	5g's for 20 min., 12cycle each of 3 orientations. Note: Use 8"*5"PCB. 031" thick 7 secure points on one long side and 2 secure points at corners of opposite sides. Parts mounted within 2' from any secure point. Test from 10-2000Hz.
	HP02: ≤10mΩ;HP03≤8 mΩ; HP05、HP06、HP10、HP11、HP12: ≤5mΩ HP07: ≤4mΩ		
ESD	$\pm(3.0\%+0.1\Omega)$	AEC-Q200-002	With the electrometer in direct contact with the discharge tip, verify the voltage setting at levels of ±500V,±1KV, ±2KV, ±4KV, ±8KV, The electrometer reading shall be within ±10% for voltages from 500V to ≅800V.
Solderability	Coverage must be over 95%.	J-STD-002	For both leaded & SMD. Electrical test not required. Magnification 50X. Conditions: a) Method B 4hrs at 155°C dry heat, the dip in bath with 245±3°C, 5±0.5s. b) Method D: at 260±3°C, 30±0.5s..
Flammability	No ignition of the tissue paper or scorching or the pinewood board	UL-94	V-0 or V-1 are acceptable. Electrical test not required.
Board Flex	$\pm(1.0\%+0.05\Omega)$	AEC-Q200-005	Bending 2mm(min) for 60+5sec
	HP02: ≤10mΩ;HP03≤8 mΩ; HP05、HP06、HP10、HP11、HP12: ≤5mΩ HP07: ≤4mΩ		
Flame Retardance	No flame	AEC-Q200-001	Only requested, when voltage/power will increase the surface temp to 350°C. Apply voltage from 9V to 32V. No flame; No explosion.
Resistance to Soldering Heat	$\pm(1.0\%+0.05\Omega)$	MIL-STD-202 Method 210	Condition B No per-heat of samples. Dipping the resistor into a solder bath having a temperature of 260°C±5°C and hold it for 10±1 seconds
	HP02: ≤10mΩ;HP03≤8 mΩ; HP05、HP06、HP10、HP11、HP12: ≤5mΩ HP07: ≤4mΩ		

10. Soldering Condition

(This is for recommendation, please customer perform adjustment according to actual application)

10.1 Recommend Reflow Soldering Profile : (solder : Sn96.5 / Ag3 / Cu0.5)

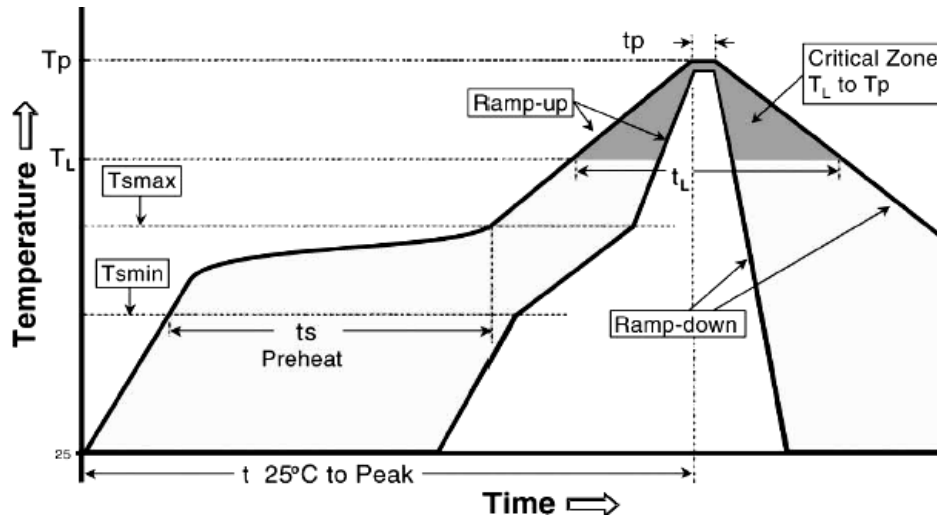

Profile Feature	Lead (Pb)-Free solder
Preheat: Temperature Min (T_{smin}) Temperature Max (T_{smax}) Time (T_{smin} to T_{smax}) (t_s)	150°C 200°C 60 -120 seconds
Average ramp-up rate : (T_{smax} to T_p)	3°C / second max.
Time maintained above : Temperature (T_L) Time (t_L)	217°C 60-150 seconds
Peak Temperature (T_p)	260°C
Time within $+0$ -5 °C of actual peak Temperature (t_p) ²	10 seconds
Ramp-down Rate	6°C/second max.
Time 25°C to Peak Temperature	8minutes max.

Allowed Re-flow times : 2 times

Remark : To avoid discoloration phenomena of chip on terminal electrodes, we suggest use N₂ Re-flow furnace .

10.2 Recommend Wave Soldering Profile : (Apply to 0603 and above size)

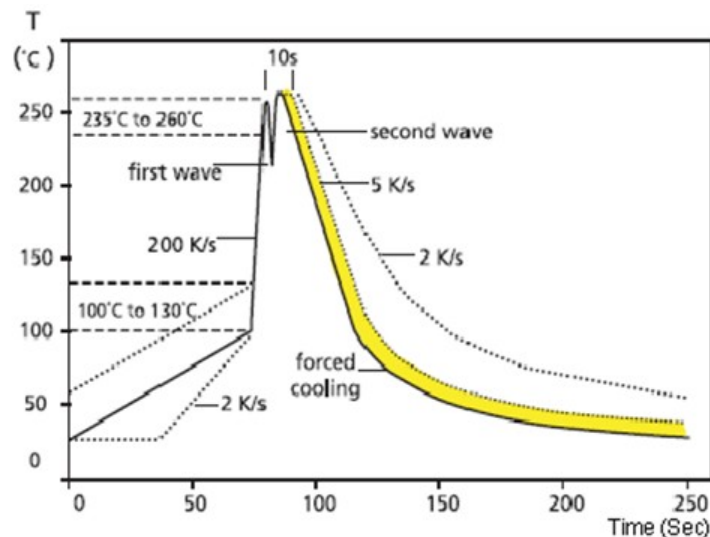

11. Packing

11.1 Dimension of Paper Taping :(Unit: mm)

Type	A ±0.1	B ±0.1	C ±0.05	$\Phi D_{-0}^{+0.1}$	E ±0.1	F ±0.05	G ±0.1	W ±0.2	T ±0.05
HP02	0.65	1.20	2.00	1.50	1.75	3.5	4.00	8.0	0.42

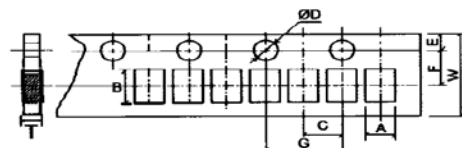

TYPE	A ±0.2	B ±0.2	C ±0.05	$\Phi D_{-0}^{+0.1}$	E ±0.1	F ±0.05	G ±0.1	W ±0.2	T ±0.10
HP03	1.10	1.90	2.00	1.50	1.75	3.5	4.00	8.00	0.67
HP05	1.65	2.40	2.00	1.50	1.75	3.5	4.00	8.00	0.81
HP06	2.00	3.60	2.00	1.50	1.75	3.5	4.00	8.00	0.81
HP07	2.80	3.50	2.00	1.50	1.75	3.5	4.00	8.00	0.75

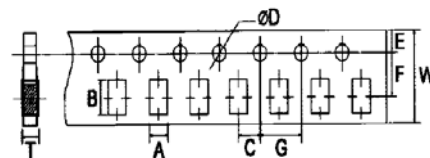

11.2 Dimension of plastic taping: (Unit: mm)

Type	A ±0.2	B ±0.2	C ±0.05	$\Phi D_{-0}^{+0.1}$	$\Phi D1_{-0}^{+0.25}$	E ±0.1	F ±0.05	G ±0.1	W ±0.2	T ±0.1
HP10	2.9	5.6	2.0	1.5	1.5	1.75	5.5	4.0	12.0	1.0
HP11	3.5	4.8	2.0	1.5	1.5	1.75	5.5	4.0	12.0	1.0
HP12	3.5	6.7	2.0	1.5	1.5	1.75	5.5	4.0	12.0	1.0

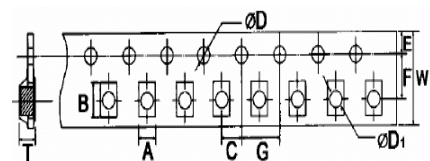

11.3 Dimension of Reel : (Unit: mm)

Type	Taping	Qty/Reel	A±0.5	B±0.5	C±0.5	$\Phi D_{\pm 1}$	$\Phi L_{\pm 2}$	W±1
HP02	Paper	10,000pcs	2.0	13.0	21.0	60.0	178.0	10.0
HP03	Paper	5,000pcs	2.0	13.0	21.0	60.0	178.0	10.0
HP05	Paper	5,000pcs	2.0	13.0	21.0	60.0	178.0	10.0
HP06	Paper	5,000pcs	2.0	13.0	21.0	60.0	178.0	10.0
HP07	Paper	5,000pcs	2.0	13.0	21.0	60.0	178.0	10.0
HP10	Embossed	4,000pcs	2.0	13.0	21.0	60.0	178.0	13.8
HP11	Embossed	4,000pcs	2.0	13.0	21.0	60.0	178.0	13.8
HP12	Embossed	4,000pcs	2.0	13.0	21.0	60.0	178.0	13.8

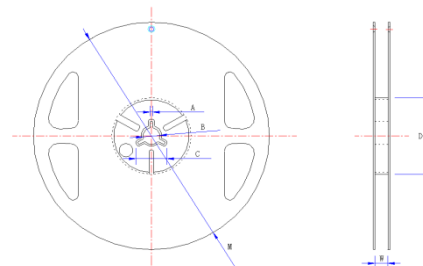

12. Note

12.1. KOME recommend the storage condition temperature: 15°C~35°C, humidity :25%~75%.

(Put condition for individual product).Even under KOME recommended storage condition, solderability of products over 1 year old. (Put condition for each product) may be degraded.

12.2. Store / transport cartons in the correct direction, which is indicated on a carton as a symbol.

Otherwise bent leads may occur due to excessive stress applied when dropping of a carton.

12.3. Product performance and soldered connections may deteriorate if the products are stored in the following places:

- Storage in high Electrostatic.
- Storage in direct sunshine、rain and snow or condensation.
- Where the products are exposed to sea winds or corrosive gases, including Cl₂, H₂S₃ NH₃, SO₂, NO₂, Br etc.