

1. Scope

1.1 This datasheet is the characteristics of Automotive Thick Film Chip Resistors manufactured by KOME Application automobile.

1.2 The test items follow the test standard of AEC-Q200.

1.3 Anti-Sulfidation

1.4 Application car, IPAD, LED Lamps, Intelligent home appliances, Medical equipment, Kinds of industrial control devices & industrial supplies

1.5 Compliant with RoHS directive.

1.6 Halogen free requirement.

2. Part Number

CQ	05	K	5	103	J	T	LF																																																										
Product Code	TYPE	T.C.R Code	Total Ch.	Resistance Value	Resistance Tolerance	Packaging Style	Other																																																										
Automotive Chip Resistors	<table border="1"> <tr><td>CQ01</td><td>0201</td></tr> <tr><td>CQ02</td><td>0402</td></tr> <tr><td>CQ03</td><td>0603</td></tr> <tr><td>CQ05</td><td>0805</td></tr> <tr><td>CQ06</td><td>1206</td></tr> <tr><td>CQ07</td><td>1210</td></tr> <tr><td>CQ10</td><td>2010</td></tr> <tr><td>CQ11</td><td>1812</td></tr> <tr><td>CQ12</td><td>2512</td></tr> </table>	CQ01	0201	CQ02	0402	CQ03	0603	CQ05	0805	CQ06	1206	CQ07	1210	CQ10	2010	CQ11	1812	CQ12	2512	<table border="1"> <tr><td>W</td><td>±200</td></tr> <tr><td>L</td><td>±250</td></tr> <tr><td>B</td><td>±300</td></tr> <tr><td>U</td><td>±400</td></tr> <tr><td>c</td><td>±50</td></tr> <tr><td>K</td><td>Based On spec.</td></tr> </table>	W	±200	L	±250	B	±300	U	±400	c	±50	K	Based On spec.	No of Total Character (103=10000=5)	<table border="1"> <tr> <td>E24</td> <td>significant figures + number of zeros</td> </tr> <tr> <td>E96</td> <td>No of character + Significant figures + number of Zeros Lead Free</td> </tr> <tr> <td colspan="2">Example</td> </tr> <tr> <td>E-24</td> <td>1R0=1.0 Ω, 103=10K Ω</td> </tr> <tr> <td>E-96</td> <td>5 1002=10K Ω</td> </tr> <tr> <td>E-96</td> <td>5 1003=100K Ω</td> </tr> <tr> <td colspan="2">Letter R is decimal point</td> </tr> </table>	E24	significant figures + number of zeros	E96	No of character + Significant figures + number of Zeros Lead Free	Example		E-24	1R0=1.0 Ω, 103=10K Ω	E-96	5 1002=10K Ω	E-96	5 1003=100K Ω	Letter R is decimal point		<table border="1"> <tr> <td>Code</td> <td>Tolerance</td> </tr> <tr> <td>F</td> <td>±1%</td> </tr> <tr> <td>J</td> <td>±5%</td> </tr> <tr> <td>G</td> <td>±2%</td> </tr> <tr> <td>0</td> <td>Jump</td> </tr> </table>	Code	Tolerance	F	±1%	J	±5%	G	±2%	0	Jump	<table border="1"> <tr> <td>T</td> <td>Tape & Reel</td> </tr> <tr> <td>B</td> <td>Bulk case</td> </tr> </table>	T	Tape & Reel	B	Bulk case	Lead free
CQ01	0201																																																																
CQ02	0402																																																																
CQ03	0603																																																																
CQ05	0805																																																																
CQ06	1206																																																																
CQ07	1210																																																																
CQ10	2010																																																																
CQ11	1812																																																																
CQ12	2512																																																																
W	±200																																																																
L	±250																																																																
B	±300																																																																
U	±400																																																																
c	±50																																																																
K	Based On spec.																																																																
E24	significant figures + number of zeros																																																																
E96	No of character + Significant figures + number of Zeros Lead Free																																																																
Example																																																																	
E-24	1R0=1.0 Ω, 103=10K Ω																																																																
E-96	5 1002=10K Ω																																																																
E-96	5 1003=100K Ω																																																																
Letter R is decimal point																																																																	
Code	Tolerance																																																																
F	±1%																																																																
J	±5%																																																																
G	±2%																																																																
0	Jump																																																																
T	Tape & Reel																																																																
B	Bulk case																																																																

3. Marking

3.1 Normally, the marking of CQ01,CQ02 resistors as following



3.2 Normally, the marking of 0Ω CQ03, 0Ω CQ05, 0Ω CQ06, 0Ω CQ07, 0Ω CQ10, 0Ω CQ12, resistors as following



0 → 0Ω

3.3 ±5% tolerance products (E-24 series):
3 codes.
1st~2nd codes are the significant figures of resistance value,
and the rest code is the power of ten.



333 → 33KΩ

3.4 ±1% tolerance products (E-96 series):
4 codes.
1st~3rd codes are the significant figures of resistance value,
and the rest code is the power of ten.
Letter "R" in mark means decimal point.



2701 → 2.7KΩ

3.5 Standard E-96 series values of CQ03 ≤±1% : due to the small size of the resistor's body, 3 digits marking will be used to indicate the accurate resistance value by using the following multiplier & resistance code.

Multiplier Code (for CQ03 ≤±1% marking)

Code	A	B	C	D	E	F	G	H	X	Y	Z
Multiplier	10 ⁰	10 ¹	10 ²	10 ³	10 ⁴	10 ⁵	10 ⁶	10 ⁷	10 ⁻¹	10 ⁻²	10 ⁻³

Standard E-96 series Resistance Value code (for CQ03 ≤±1% marking)

Value	Code	Value	Code	Value	Code	Value	Code
100	01	178	25	316	49	562	73
102	02	182	26	324	50	576	74
105	03	187	27	332	51	590	75
107	04	191	28	340	52	604	76
110	05	196	29	348	53	619	77
113	06	200	30	357	54	634	78
115	07	205	31	365	55	649	79
118	08	210	32	374	56	665	80
121	09	215	33	383	57	681	81
124	10	221	34	392	58	698	82
127	11	226	35	402	59	715	83
130	12	232	36	412	60	732	84
133	13	237	37	422	61	750	85
137	14	243	38	432	62	768	86
140	15	249	39	442	63	787	87
143	16	255	40	453	64	806	88
147	17	261	41	464	65	825	89
150	18	267	42	475	66	845	90
154	19	274	43	487	67	866	91
158	20	280	44	499	68	887	92
162	21	287	45	511	69	909	93
165	22	294	46	523	70	931	94
169	23	301	47	536	71	953	95
174	24	309	48	549	72	976	96

So the resistance value are marked as the following examples



$$1.96K\Omega = 196 \times 10^1 \Omega = 29B$$



3.6 Standard E-24 and not belong to E-96 series values ($\leq \pm 1\%$) of 0603 size: the marking is the same as 5% tolerance but marking as underline.



$$\underline{333} = 33K\Omega$$



$$\underline{680} = 68\Omega$$

4. Dimension

Type	Dimension(mm)				
	L	W	H	A	B
CQ01(0201)	0.60±0.03	0.30±0.03	0.23±0.03	0.12±0.05	0.15±0.05
CQ02(0402)	1.00±0.10	0.50±0.05	0.35±0.05	0.20±0.10	0.25±0.10
CQ03(0603)	1.60±0.10	0.80±0.10	0.45±0.10	0.30±0.20	0.30±0.20
CQ05(0805)	2.00±0.15	1.25 +0.15/-0.10	0.55±0.10	0.40±0.20	0.40±0.20
CQ06(1206)	3.10±0.15	1.55+0.15/-0.10	0.55±0.10	0.45±0.20	0.45±0.20
CQ07(1210)	3.10±0.10	2.50±0.15	0.55±0.10	0.50±0.25	0.50±0.20
CQ10(2010)	5.00±0.10	2.50±0.20	0.55±0.10	0.60±0.25	0.50±0.20
CQ12(2512)	6.35±0.10	3.20±0.20	0.55±0.10	0.60±0.25	0.50±0.20

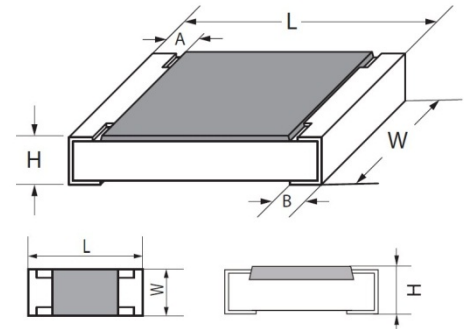

5. Resistance Range

Type	Power Rating	Resistance Range			
		±0.5%	±1.0%	±2.0%	±5.0%
CQ01	1/20W	---	1Ω-10MΩ	1Ω-10MΩ	1Ω-10MΩ
CQ02	1/16W	1Ω-10MΩ	0.1Ω-10MΩ	0.1Ω-10MΩ	0.1Ω-10MΩ
CQ03	1/10W	1Ω-10MΩ	0.01Ω-10MΩ	0.01Ω-10MΩ	0.01Ω-10MΩ
CQ05	1/8W	1Ω-10MΩ	0.1Ω ≤ R < 10MΩ	0.1Ω ≤ R < 10MΩ	0.1Ω ≤ R < 10MΩ
	1/4W	---	0.01Ω ≤ R < 0.1Ω	0.01Ω ≤ R < 0.1Ω	0.01Ω ≤ R < 0.1Ω
CQ06	1/4W	1Ω-10MΩ	0.1Ω ≤ R < 10MΩ	0.1Ω ≤ R < 10MΩ	0.1Ω ≤ R < 10MΩ
	1/3W	---	0.01Ω ≤ R < 0.1Ω	0.01Ω ≤ R < 0.1Ω	0.01Ω ≤ R < 0.1Ω
CQ07	1/2W	1Ω-10MΩ	0.01Ω-10MΩ	0.01Ω-10MΩ	0.01Ω-10MΩ
CQ10	3/4W	1Ω-10MΩ	0.01Ω-10MΩ	0.01Ω-10MΩ	0.01Ω-10MΩ
CQ12	1W	1Ω-10MΩ	0.01Ω-10MΩ	0.01Ω-10MΩ	0.01Ω-10MΩ

6. Ratings

Type	Max. Working Voltage	Max. Overload Voltage	Dielectric withstanding Voltage	Resistance Value of Jumper	Rated Current of Jumper	Max. Overload Current of Jumper	Operating Temperature
CQ01	25V	50V	/	<50mΩ	0.5A	1A	-55°C~155°C
CQ02	50V	100V	100V	<50mΩ	1A	2A	-55°C~155°C
CQ03	75V	150V	300V	<50mΩ	1A	2A	-55°C~155°C
CQ05	150V	300V	500V	<50mΩ	2A	5A	-55°C~155°C
CQ06	200V	400V	500V	<50mΩ	2A	10A	-55°C~155°C
CQ07	200V	500V	500V	<50mΩ	2A	10A	-55°C~155°C
CQ10	200V	500V	500V	<50mΩ	2A	10A	-55°C~155°C
CQ12	200V	500V	500V	<50mΩ	2A	10A	-55°C~155°C

7. Soldering pad size recommended

Type	Dimension(mm)			
	A	B	C	D
CQ01	0.3±0.05	0.35±0.05	0.4±0.05	1.0±0.05
CQ02	0.50±0.05	0.45±0.05	0.5±0.05	1.4±0.05
CQ03	0.8±0.05	0.65±0.05	0.8±0.05	2.1±0.05
CQ05	1.0±0.1	1.0±0.1	1.3±0.1	3.0±0.1
CQ06	2.0±0.1	1.1±0.1	1.6±0.1	4.2±0.1
CQ07	2.0±0.1	1.1±0.1	2.6±0.1	4.2±0.1
CQ10	3.6±0.1	1.3±0.1	2.6±0.1	6.2±0.1
CQ12	4.9±0.1	1.6±0.1	3.3±0.1	8.1±0.1

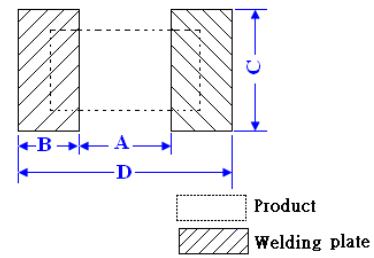

8. Derating Curve

Power rating will change based on continuous load at ambient temperature from -55 to 155°C. It is constant between -55 to 70°C, and derate to zero when temperature rise from 70 to 155°C.

Voltage rating:

Resistors shall have a rated direct-current (DC) continuous working voltage or an approximate sine-wave root-mean-square (RMS) alternating-current (AC) continuous working voltage at commercial-line frequency and waveform corresponding to the power rating, as determined from the following formula:

$$RCWV = \sqrt{P \times R}$$

Remark: RCWV: Rating Continuous Working Voltage (Volt.) P: power rating (Watt) R: nominal resistance (Ω) In no case shall the rated DC or RMS AC continuous working voltage be greater than the applicable maximum value. The overload voltage is 2.5 times RCWV or Max. Overload voltage whichever is lower.

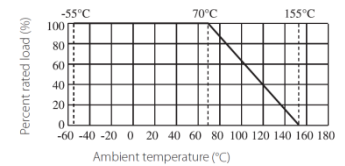

9. Structure

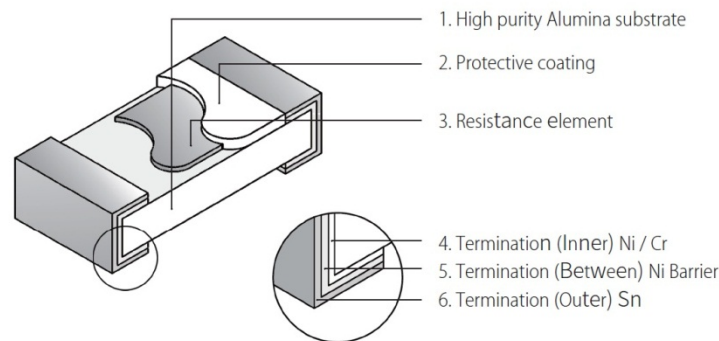

10. Performance Specification

Characteristic	Limits	Ref. Standards	Test Methods
Operational life	±2%, ±5% : ±(3.0%+0.1Ω) ±0.5%, ±1% : ±(1.0%+0.1Ω)	MIL-STD-202 Method 108	125°C, at 36% of operating power, 1000H(1.5 hours "ON", 0.5 hour "OFF"). Measurement at 24±4hours after test conclusion.
	<100mΩ		Apply to rate current for 0 Ω
Electrical Characterization (T.C.R)	CQ01: 1Ω≤R≤10Ω: -100~+350PPM/°C > 10Ω: ±200PPM/°C	GB/T 5729 4.8 JIS-C-5201 4.8 IEC 60115-1 6.2	Natural resistance changes per temp. Degree centigrade $\frac{R_2 - R_1}{R_1(t_2 - t_1)} \times 10^6$ (PPM/°C) R ₁ : Resistance Value at room temperature (t ₁) ; R ₂ : Resistance at test temperature (t ₂) t ₁ : +25°C or specified room temperature t ₂ : Test temperature (-55°C or 125°C)
	CQ02: 0.1Ω≤R<1Ω: ±800PPM/°C 1Ω≤R≤10Ω: ±200PPM/°C >10Ω: ±100PPM/°C		

Short-time overload	$\pm 0.5\%, \pm 1\%: \pm(1.0\%+0.05\Omega)$ $\pm 2\%, \pm 5\%: \pm(2.0\%+0.05\Omega)$	GB/T 5729 4.13 JIS-C-5201 4.13 IEC 60115-1 8.1.4.2	Permanent resistance change after the application of a potential of 2.5 times RCWV or Max. Overload Voltage whichever less for 5 seconds.. Apply max Overload current for 0Ω
	<50mΩ		
External Visual	Marking Complete , no mechanical damage	MIL-STD-883 Method 2009	Electrical test not required. Inspect device construction, marking and workmanship
Physical Dimension	Reference 5.0 Dimension Standards	JESD22 MH Method JB-100	Verify physical dimensions to the applicable device detail specification. Note: User(s) and Suppliers spec. Electrical test not required.
Resistance to Solvent	Marking Complete , no mechanical damage	MIL-STD-202 Method 215	Note: Add Aqueous wash chemical – OKEM Clean or equivalent. Do not use banned solvents.
Terminal Strength	Not broken	AEC-Q200-006	0201:2N,0402:5N; others:17.7N, 60±1 seconds.
High Temperature Exposure (Storage)	$\pm(1.0\%+0.1\Omega)$	MIL-STD-202 Method 108	1000hrs. @T=155°C.Unpowered. Measurement at 24±4 hours after test conclusion.
	<100mΩ		
Temperature Cycling	$\pm(1.0\%+0.1\Omega)$	JESD22 Method JA-104	1000 Cycles (-55°C to +155°C). Measurement at 24±4 hours after test conclusion.
	<100mΩ		
Biased Humidity	$\pm 2\%, \pm 5\%: \pm(3.0\%+0.05\Omega)$ $\pm 0.5\%, \pm 1\%: \pm(1.0\%+0.05\Omega)$	MIL-STD-202 Method 103	1000 hours 85°C, 85%RH. Note: Specified conditions: 10% of operating power. Measurement at 24±4 hours after test conclusion. Apply to rate current for 0 Ω
	<100mΩ		
Mechanical Shock	$\pm(1.0\%+0.1\Omega)$	MIL-STD-202 Method 213	Half sine wave, acceleration 100g's, each three times in X, Y and Z directions, pulse width 6ms.
Vibration	$\pm(1.0\%+0.1\Omega)$	MIL-STD-202 Method 204	5g's for 20 min., 12cycle each of 3 orientations. Note: Use 8"*5"PCB. 031" thick 7 secure points on one long side and 2 secure points at corners of opposite sides. Parts mounted within 2' from any secure point. Test from 10-2000Hz.
ESD	$\pm(3.0\%+0.1\Omega)$	AEC-Q200-002	With the electrometer in direct contact with the discharge tip, verify the voltage setting at levels of $\pm 500V, \pm 1KV, \pm 2KV, \pm 4KV, \pm 8KV$, The electrometer reading shall be within $\pm 10\%$ for voltages from 500V to $\cong 800V$.
Solderability	Coverage must be over 95%.	J-STD-020E	For both leaded & SMD. Electrical test not required. Magnification 50X. Conditions: a) Method B 4hrs at 155°C dry heat, the dip in bath with 245°C, 5s. b) Method D: at 260°C, 30±0.5s.
Flammability	No ignition of the tissue paper or scorching or the pinewood board	UL-94	V-0 or V-1 are acceptable. Electrical test not required.
Board Flex	$\pm(1.0\%+0.05\Omega)$	AEC-Q200-005	Bending 2mm(min) for 60+5sec
	<50mΩ		
Flame Retardance	No flame	AEC-Q200-001	Only requested, when voltage/power will increase the surface temp to 350°C. Apply voltage from 9V to 32V. No flame; No explosion.
Resistance to Soldering Heat	$\pm(1.0\%+0.05\Omega)$	MIL-STD-202 Method 210	Condition B No per-heat of samples. Dipping the resistor into a solder bath having a temperature of 260°C±5°C and hold it for 10±1 seconds
	<50mΩ		
Sulfuration test	$\pm(1.0\%+0.05\Omega)$	ASTM B-809-95	Sulfur(saturated vapor) , Temperature: 60±2°C Humidity: 86 ~ 90%RH, 1000H .

11. Soldering Condition

(This is for recommendation, please customer perform adjustment according to actual application)

11.1 Recommend Reflow Soldering Profile : (solder : Sn96.5 / Ag3 / Cu0.5)

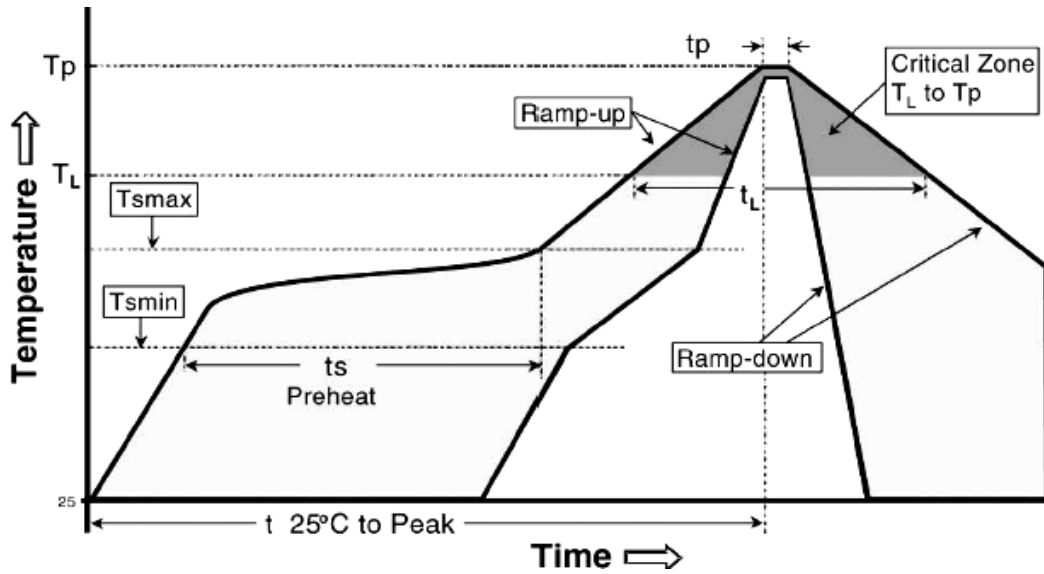

Profile Feature	Lead (Pb)-Free solder
Preheat: Temperature Min ($T_{s_{min}}$) Temperature Max ($T_{s_{max}}$) Time ($T_{s_{min}}$ to $T_{s_{max}}$) (t_s)	150°C 200°C 60 -120seconds
Average ramp-up rate : ($T_{s_{max}}$ to T_p)	3°C / second max.
Time maintained above : Temperature (T_L) Time (t_L)	217°C 60-150 seconds
Peak Temperature (T_p)	260°C
Time within $+0$ -5 °C of actual peak Temperature (t_p) ²	10 seconds
Ramp-down Rate	6°C/second max.
Time 25°C to Peak Temperature	8minutes max.

Allowed Re-flow times : 2 times

Remark : To avoid discoloration phenomena of chip on terminal electrodes, we suggest use N₂ Re-flow furnace .

11.2 Recommend Wave Soldering Profile : (Apply to 0603 and above size)

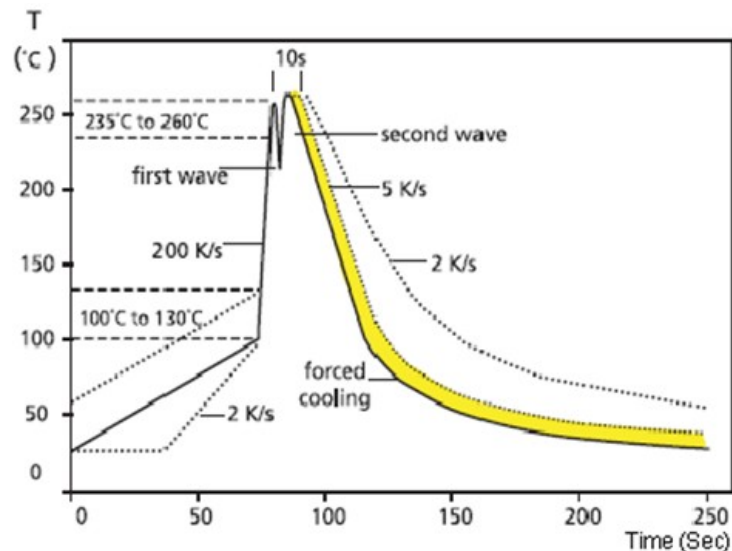

12. Packing

12.1 Dimension of Paper Taping :(Unit: mm)

Type	A	B	C ±0.05	$\Phi D_{-0}^{+0.1}$	E ±0.1	F ±0.05	G ±0.1	W ±0.2	T
CQ01	0.40±0.05	0.70±0.05	2.00	1.50	1.75	3.50	4.00	8.00	0.42±0.1
CQ02	0.65±0.1	1.20±0.1	2.00	1.50	1.75	3.50	4.00	8.00	0.42±0.05

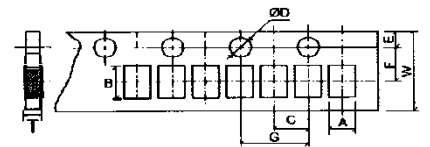

Type	A ±0.2	B ±0.2	C ±0.05	$\Phi D_{-0}^{+0.1}$	E ±0.1	F ±0.05	G ±0.1	W ±0.2	T ±0.1
CQ03	1.10	1.90	2.00	1.50	1.75	3.50	4.00	8.00	0.67
CQ05	1.65	2.40	2.00	1.50	1.75	3.50	4.00	8.00	0.81
CQ06	2.00	3.60	2.00	1.50	1.75	3.50	4.00	8.00	0.81
CQ07	2.80	3.50	2.00	1.50	1.75	3.50	4.00	8.00	0.75

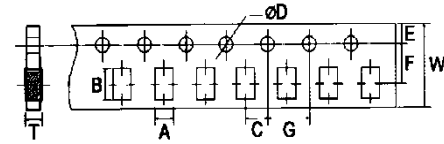

12.2 Dimension of plastic taping: (Unit: mm)

Type	A ±0.2	B ±0.2	C ±0.05	$\Phi D_{-0}^{+0.1}$	$\Phi D1_{-0}^{+0.25}$	E ±0.1	F ±0.05	G ±0.1	W ±0.2	T ±0.1
CQ10	2.90	5.60	2.00	1.50	1.50	1.75	5.50	4.00	12.00	1.00
CQ12	3.50	6.70	2.00	1.50	1.50	1.75	5.50	4.00	12.00	1.00

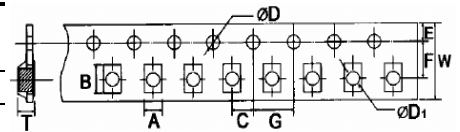

12.3 Dimension of Reel : (Unit: mm)

Type	Taping	Qty/Reel	A±0.5	B±0.5	C±0.5	D±1	M±2	W±1
CQ01	Paper	15,000pcs	2.0	13.0	21.0	60.0	178.0	10.0
CQ02	Paper	10,000pcs	2.0	13.0	21.0	60.0	178.0	10.0
CQ03	Paper	5,000pcs	2.0	13.0	21.0	60.0	178.0	10.0
CQ05	Paper	5,000pcs	2.0	13.0	21.0	60.0	178.0	10.0
CQ06	Paper	5,000pcs	2.0	13.0	21.0	60.0	178.0	10.0
CQ07	Paper	5,000pcs	2.0	13.0	21.0	60.0	178.0	10.0
CQ10	Embossed	4,000pcs	2.0	13.0	21.0	60.0	178.0	13.8
CQ12	Embossed	4,000pcs	2.0	13.0	21.0	60.0	178.0	13.8

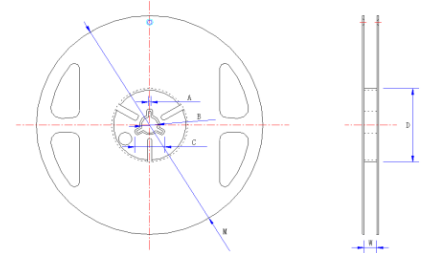

13. Note

13.1. KOME recommend products store in warehouse with temperature between 15 to 35°C under humidity between 25 to 75%RH.

Even under storage conditions recommended above, solder ability of products will be degraded stored over 1 year old.

13.2. Cartons must be placed in correct direction which indicated on carton, otherwise the reel or wire will be deformed.

13.3. Storage conditions as below are inappropriate:

- Stored in high electrostatic environment
- Stored in direct sunshine, rain, snow or condensation.

13.4 This product is used for automotive electronics. KOME will not be responsible for any damage, expense or loss caused by the use of this specification in any special environment. This series of products are suitable for automotive electronics applications, as shown below,

If there are other applications, you need to confirm with KOME whether they are applicable:

- Control unit for information, entertainment, navigation, audio;
- Control unit for comfortable doors, windows, seat;
- Control unit for internal lighting.