



# 产品规格书

## PRODUCT SPECIFICATION

客户名称

CUSTOMER

产品系列

KHBWS 系列绕线片式高频电感器

PRODUCT SERIES

KHBWS SERIES WIRE WOUND CERAMIC CHIP  
INDUCTOR

规格型号

PRODUCT TYPE

客户型号规格

CUSTOMER'S PRODUCT TYPE

研发	品质	业务	批准

备注 REMARK:

客户回签 CUSTOMER APPROVAL

--	--	--

**变更履历 Change list**

序号 NO.	修改日期 DATE	修改内容 CHANGE CONTENT	版本号 Version NO.
1	2014.10.14	初版 First edition	A1
2	2019.11.29	更新联系方式 Update contact	A2
3	2024.9.25	修正尺寸标注 Correct dimensions	A4

## 1 用途 APPLICATIONS

广泛应用于讯通产品，如移动电话、电视、收音机及其他电子设备。

The KHBWS series is widely used in the communication applications, such as cellular phones, television tuners, radios, and other electronic devices.

## 2 特点 FEATURES

较高自谐频率，良好的品质因数，稳定的电气特性。

Higher self-resonate frequency, better Q factor, and much stable performance.

良好的焊锡性及耐热性。

Excellent solderability and resistance to soldering heat.

尺寸标准，结构可靠，适用于 SMT 工艺。

Standard dimensions, high reliability, and easy surface mount assembly.

各种电感量可供选择。

Wide range of inductance value for flexible needs.

## 3 产品编码 PRODUCT IDENTIFICATION

KHBWS 1608 - R10 J

①                      ②                      ③                      ④

①	Type: Wire Wound Chip Inductor
②	External Dimensions (L×W) (mm): 1.6×0.8
③	Nominal Inductance: 1N0, 1.0nH; 47N, 47nH; R10, 0.1μH; 1R0, 1.0μH
④	Inductance Tolerance: F, ±1%; G, ±2%; J, ±5%; K, ±10%; M, ±20%;

## 4 外形及尺寸 SHAPE AND DIMENSIONS

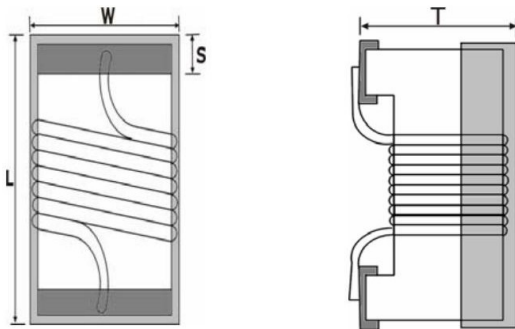

Unit: mm

Type	L(max)	W(max)	T(max)	S(typ.)
KHBWS100 5	1.19	0.66	0.64	0.20
KHBWS160 8	1.80	1.12	0.95	0.35
KHBWS201 2	2.29	1.73	1.52	0.40

## 5 特性参数 SPECIFICATIONS

详见附录 A。Please refer to Appendix A.

工作温度范围 Operating temperature range: -40°C~+85°C

储存温度范围 Storage temperature range: -10°C~+40°C, 70% RH.

## 6 测试及可靠性 TESTING AND RELIABILITY

### 6.1 测试环境条件 Test Conditions

一般按照以下环境条件测试（有特殊要求的除外），：

Unless otherwise specified, the standard atmospheric conditions for measurement/test as:

- a. 温度 Ambient Temperature: 20±15°C
- b. 湿度 Relative Humidity: 65±20%
- c. 大气压 Air Pressure: 86 kPa to 106 kPa

如果对测试结果有疑义，可以按照以下条件复测：

If any doubt on the results, measurements/tests should be made within the following limits:

- a. 温度 Ambient Temperature: 20±2°C
- b. 湿度 Relative Humidity: 65±5%
- c. 大气压 Air Pressure: 86kPa to 106 kPa

## 6.2 测试及可靠性 Testing and reliability

测试与可靠性 Testing and reliability	测试方法与要求 Test Methods and Remarks
直流电阻 RDC	a 标准值参考第 5 章节附录 A。Refer to Item 5 Appendix A. b 测试仪器：高精度电阻表 HP4338B 或等效仪器。Test equipment (Analyzer): High Accuracy Milliohmmeter-HP4338B or equivalent.
电感量 Inductance ( Z )	a 标准值参考第 5 章节附录 A。Refer to Item 5 Appendix A. b 测试仪器：高精度射频阻抗分析仪 Anglient E4991A+HP16192A 或等效仪器。 Test equipment: High Accuracy RF Inductance /Material Analyzer -Anglient E4991A+ HP16192A or equivalent. c 测试信号 Test signal: -40dBm or 100mV. d 测试频率参考第 5 章节。Test frequency refers to Item 5.
品质因数 Q	a 标准值参考第 5 章节。Refer to Item 5. b 测试仪器：高精度射频阻抗分析仪 Anglient E4991A+HP16192A 或等效仪器。 Test equipment: High Accuracy RF Inductance /Material Analyzer -Anglient E4991A+ HP16192A or equivalent. c 测试信号 Test signal: -40dBm or 100mV. d 测试频率参考第 5 章节。Test frequency refers to Item 5.
额定电流 Rated Current (Ir)	a 标准值参考第 5 章节。Refer to Item 5. b 测试仪器：HP6632B 直流电源，数字点温计或等效仪器。 Test equipment: HP6632B system DC power supply, digital surface thermometer or equivalent. c 额定电流 <1A，温升 $\Delta T \leq 20^\circ\text{C}$ ；额定电流 $\geq 1\text{A}$ ，温升 $\Delta T \leq 40^\circ\text{C}$ 。Rated Current <1A, $\Delta T \leq 20^\circ\text{C}$ ； Rated Current $\geq 1\text{A}$ , $\Delta T \leq 40^\circ\text{C}$ .
可焊性 SOLDER – ABILITY	至少 95%的焊接面完全被焊锡连续覆盖。95% min. coverage of all metabolised area. 焊锡温度 Solder temp. : 240±5°C 浸入时间 Immersion time : 3±1 sec 焊锡 Solder : Sn-3Ag-0.5Cu
耐焊性 RESISTANCE TO SOLDER HEAT	无可见损伤。电特性和机械特性满足产品规范或检验标准要求。No visible damage. Electrical characteristics and mechanical characteristics shall be satisfied. 焊锡温度 Solder Temp. : 265±3°C 浸入时间 Immersion time : 6±1 sec 预热 Preheating : 100°C to 150°C, 1 minute. 在室温下放置 24±2 小时后测试检查。Measurement to be made after keeping at room temp for 24±2 hrs. 焊锡 Solder : Sn-3Ag-0.5Cu

<p>弯曲 Bend</p>	<p>试验后无破损现象，电感量应在±20%以内，直流电阻应符合标准/规范要求。 Without deformation cases, Inductance shall be satisfied ± 20%, DC resistance shall be satisfied.</p> <p>将产品焊接在试验板上，如图所示在试验板中间位置施加压力，使得试验板中心点向下弯曲2mm，保持10秒。After soldering a chip to a test substrate, bend the substrate by 2mm hold for 10s and then return.</p> <p>Soldering shall be done in accordance with the recommended PC board pattern and reflow soldering.</p>	
<p>振动 Vibration</p>	<p>a.试验要求 Performance specification</p> <ol style="list-style-type: none"> <li>外观 Appearance: 无可见机械损伤 no mechanical damage</li> <li>电感量变化应在±20%以内 Inductance shall be with ±20 % of the initial value</li> </ol> <p>b.试验条件 Test condition</p> <ol style="list-style-type: none"> <li>波形 Waveform: 正弦波 Sine wave</li> <li>频率 Frequency: 10~55~10 Hz</li> <li>持续时间 Sweep time: 1min</li> <li>Amplitude: 1.5mm(peak-peak)</li> <li>Direction: X,Y,Z(3 axes)</li> <li>Duration: 2 hrs./axis, total 6 hrs.</li> </ol>	
<p>温度冲击 Temperature shock</p>	<p>a.试验要求 Performance specification</p> <ol style="list-style-type: none"> <li>外观 Appearance: 无可见机械损伤 no mechanical damage</li> <li>电感量变化应在±20%以内 Inductance shall be with ±20 % of the initial value</li> </ol> <p>b.试验条件 Test condition</p> <ol style="list-style-type: none"> <li>温度 Temperature : -40°C,+85°C各保持 30 分钟。-40°C,+85°C kept stabilized for 30 minutes each</li> <li>周期 Cycle: 5 次。5 cycles.</li> <li>检查 Measurement: 试验后至少在室温条件下放置 24 小时以上。After placing at room ambient temperature for 24 hours minimum.</li> </ol>	
<p>湿热负载 HUMIDITY RESISTANCE</p>	<p>a.试验要求 Performance specification</p> <ol style="list-style-type: none"> <li>外观 Appearance: 无可见机械损伤 no mechanical damage</li> <li>电感量变化应在±20%以内 Inductance shall be with ±20 % of the initial value</li> </ol> <p>b.试验条件 Test condition</p> <ol style="list-style-type: none"> <li>湿度 Humidity: 90 to 95 % RH</li> <li>温度 Temperature: 60±2°C</li> <li>加载电流 Applied current: 额定直流电流 Rated current</li> <li>试验时间 Testing time: 1000 (+48,0) hours</li> <li>检查 Measurement: 试验后至少在室温条件下放置 24 小时以上。After placing at room ambient temperature for 24 hours minimum.</li> </ol>	
<p>高温负载 HIGH TEMPERATURE RESISTANCE</p>	<p>a. 试验要求 Performance specification</p> <ol style="list-style-type: none"> <li>外观 Appearance: 无可见机械损伤 no mechanical damage</li> <li>电感量变化应在±20%以内 Inductance shall be with ±20 % of the initial value</li> </ol> <p>b. 试验条件 Test condition</p> <ol style="list-style-type: none"> <li>温度 Temperature: +85°C±2°C</li> <li>加载电流 Applied current: 额定直流电流 Rated current</li> <li>试验时间 Testing time: 1000 (+48,0) hours</li> <li>检查 Measurement: 试验后至少在室温条件下放置 24 小时以上。After placing at room ambient temperature for 24 hours minimum.</li> </ol>	
<p>低温储存 LOW TEMPERATURE STORAGE LIFE</p>	<p>a.试验要求 Performance specification</p> <ol style="list-style-type: none"> <li>外观 Appearance: 无可见机械损伤 no mechanical damage.</li> <li>电感量变化应在±20%以内 Inductance shall be with ±20 % of the initial value.</li> </ol> <p>b.试验条件 Test condition</p> <ol style="list-style-type: none"> <li>温度 Temperature: -40°C±2°C</li> </ol>	

	2. 试验时间 Testing time: 1000 (+48,0) hours 3. 检查 Measurement: 试验后至少在室温条件下放置 24 小时以上。After placing for 24 hours minimum at room ambient temperature.
端头强度 TERMINAL STRENGTH	无破损现象。Without deformation cases. 电感量变化应在±20%以内。Inductance shall be satisfied ± 20%. 直流电阻应满足标准要求。DC resistance shall be satisfied. 焊接在 PCB 上的产品应持续成熟 10N 推力共 10 秒, 0603[0201]产品推力为 2N。Solder chip on PCB and applied 10N(1.02Kgf) for 10 sec.0603[0201] chip applied 2N.
盐雾 Salt mist	a. 试验要求 Performance specification 1) 外观 Appearance: 无可见机械损伤 no mechanical damage. 2) 电感量变化应在±20%以内 Inductance shall be with ±20 % of the initial value. b. 试验条件 Test condition 1) 盐溶液溶度 Concentration of salt solution: (5±0.1) %. 2) PH: 6.5-7.2 3) 时间 Time: 48±2h

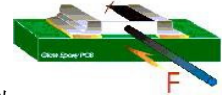

## 7 包装及储存 Packaging, Storage

### 7.1 包装 Packaging

(1) 载带尺寸 Tape Dimensions(Unit: mm)

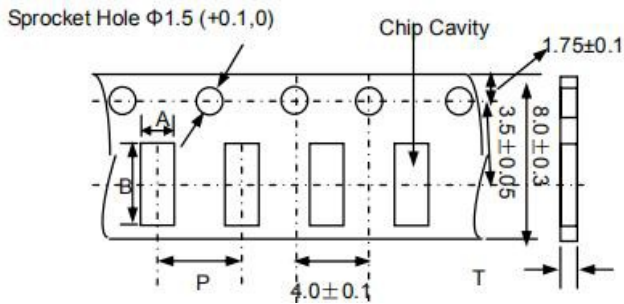

Paper Tape				
型号 Type	A	B	P	Tmax
HBWS1005	0.74±0.15	1.23±0.15	2.0±0.1	0.65

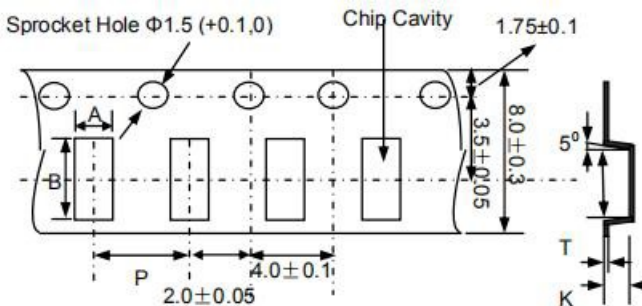

EMbossed Tape					
型号 Type	A	B	P	Kmax	Tmax
HBWS1608	1.15±0.2	1.85±0.2	4.0±0.1	1.15	0.3
HBWS2012	1.85±0.2	2.40±0.2	4.0±0.1	1.65	0.3

## (2) 载带 Tape

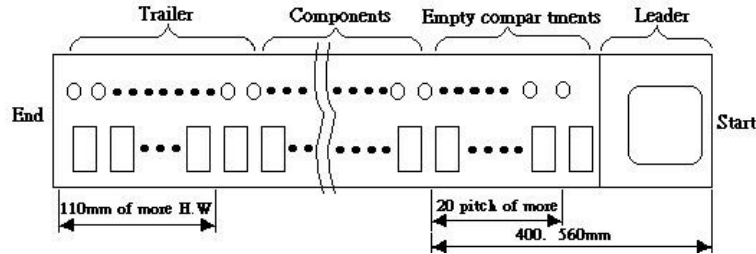

## (3) 卷盘 REEL

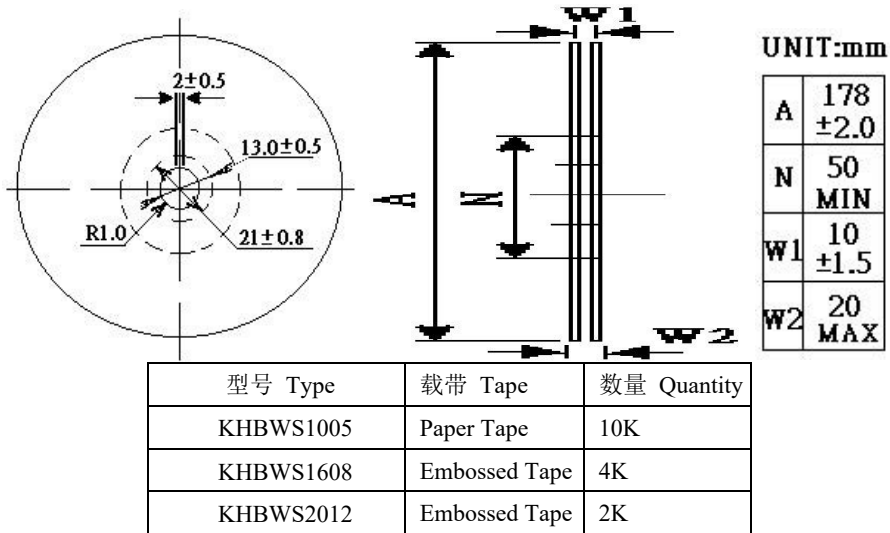

## (4) 剥离力 PEELING OFF FORCE

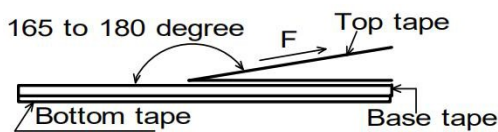

剥离速度 Speed of peeling off	300mm/s
剥离力 Peeling off force	0.1N to 1N(10g to 100g).

## (5) 包装 Packaging

- 卷盘和干燥剂一同放入尼龙或塑料袋中。Reel and a bag of desiccant shall be packed in Nylon or plastic bag.
- 每个内盒中最多装 2 个上述袋子。Maximum of 2 bags shall be packaged in a inner box.
- 每个外箱中最多装 8 个内盒。Maximum of 8 inner box shall be packaged in a outer box.

## 7.2 储存 Storage

7.2.1 不得暴露在高温高湿环境下储存，否则导致产品外电极和焊接性恶化变差。建议包装好的产品储存在低于 40°C、小于 70% RH 条件下。The solderability of the external electrode may be deteriorated if packages are stored where they are exposed to high humidity. Packages must be stored at 40°C or less and 70% RH or less.

7.2.2 不得暴露在灰尘或腐蚀性气体（如氯化氢，亚硫酸气体或硫化氢等）环境下储存，否则会导致产品外电极和焊接性恶化变差。The solderability of the external electrode may be deteriorated if packages are stored where they are exposed to dust or harmful gas (hydrogen chloride, sulfurous acid gas or hydrogen sulfide).

7.2.3 如果暴露在阳光直射或加热环境下储存，会导致包装材料变形。Packaging material may be deformed if packages are stored where they are exposed to heat or direct sunlight.

7.2.4 采用聚乙烯热封载带形式的最小包装，在使用之前不要拆开。如果拆开了，应尽快使用卷盘保护起来。Minimum packages, such as polyvinyl heat-seal packages shall not be opened until just before they are used.If opened, use the reels as soon as possible.

7.2.5 在符合 8.2.1 和 8.2.2 要求的环境下储存，从产品发货日期开始 6 个月内，产品的焊接性能够满足 7.2 规定的要求。Solderability specified in composite specification 7.2 shall be for 6 months from the date of delivery on condition that they are stored at the environment specified clause 8.2.1 & 8.2.2.

在产品使用之前，如果储存期超过 6 个月，则需要复检焊接性。For those parts which passed more than 6 months shall be checked solderability before it is used.

## 8 安装使用及注意事项

### 8.1 回流焊条件 Reflow soldering conditions

焊接之前产品应预热到 150°C。焊接后应冷却到 100°C。Pre-heating should be in such a way that the temperature difference between solder and ferrite surface is limited to 150°C max.Also cooling into solvent after soldering should be in such a way that the temperature difference is limited to 100°C max.

如果预热不充分，会导致产品质量恶化。Unenough pre-heating may cause cracks on the ferrite, resulting in the deterioration of product quality.

产品应当按照下述曲线焊接。Products should be soldered within the following allowable range indicated by the slanted line.

作业前，应对焊锡炉进行校准确认，保证能够符合焊接工艺条件。The excessive soldering conditions may cause the corrosion of the electrode, When soldering is repeated, allowable time is the accumulated time.

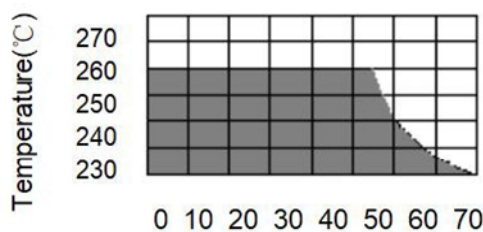

Temperature Profile

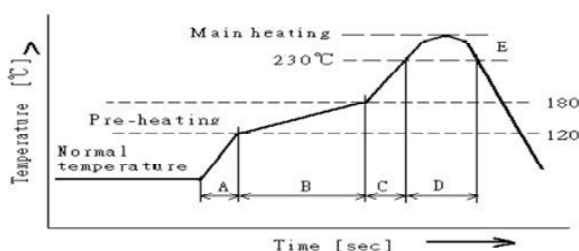

A	Slope of temp. rise	※ 1 to 5	※ °C/sec
B	Heat time	50 to 150	※ sec
	Heat temperature	120 to 180	※ °C
C	Slope of temp. rise	1 to 5	※ °C/sec
D	Time over 230°C	90~120	※ sec
E	Peak temperature	255~260	※ °C
	Peak hold time	10 max.	※ sec
※ No. of mounting		3	※ times

### 8.2 返工 Reworking with soldering iron

预热 Preheating	150°C, 1 minute
最高温度 Tip temperature	280°C max
焊接时间 Soldering time	3seconds max.

电烙铁输出功率 Soldering iron output	30w max.
电烙铁焊头尺寸 End of soldering iron	φ 3mm max.

\*返工仅限一次。Reworking should be limited to only one time.

注意 Note: 为了避免焊接高温冲击导致产品本体开裂, 电烙铁焊头焊锡时应避免直接与产品接触。Do not directly touch the products with the tip of the soldering iron in order to prevent the crack on the ferrite material due to the thermal shock.

### 8.3 焊料量 Solder Volume

焊料使用时, 不得超过如下所示的上限要求。Solder shall be used not to be exceed the upper limits as shown below.

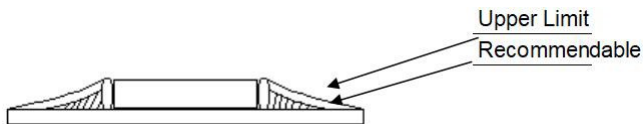

随着焊料的增加, 产品承受的机械应力也随之增加。过量的焊料所产生的机械应力, 会导致产品出现机械或电气特性失效。Accordingly increasing the solder volume, the mechanical stress to product is also increased. Exceeding solder volume may cause the failure of mechanical or electrical performance.



附录 A 电气特性表  
Appendix A Electrical Characteristics

KHBWS1005 Series

Part Number	Inductance	Mini. Quality Factor	L,Q test frequency	Mini.self resonant frequency	Max.DC resistance	Max.rated Current
Unit	nH	-	MHz	GHz	$\Omega$	mA
Symbol	L	Q	Freq.	S.R.F	DCR	Ir
KHBWS1005-1N0	1	16	250	12.7	0.045	1360
KHBWS1005-1N2	1.2	12	250	12.9	0.09	740
KHBWS1005-1N3	1.3	10	250	12.9	0.14	640
KHBWS1005-1N4	1.4	10	250	6	0.13	740
KHBWS1005-1N5	1.5	10	250	12.9	0.14	640
KHBWS1005-1N8	1.8	20	250	12	0.07	1040
KHBWS1005-1N9	1.9	20	250	11.3	0.07	1040
KHBWS1005-2N0	2	23	250	11.1	0.07	1040
KHBWS1005-2N2	2.2	22	250	10.8	0.07	960
KHBWS1005-2N4	2.4	22	250	10.5	0.068	790
KHBWS1005-2N7	2.7	16	250	10.4	0.12	640
KHBWS1005-3N0	3	24	250	7	0.066	840
KHBWS1005-3N3	3.3	24	250	7	0.066	840
KHBWS1005-3N6	3.6	24	250	6.8	0.066	840
KHBWS1005-3N9	3.9	24	250	6	0.066	840
KHBWS1005-4N3	4.3	22	250	6	0.091	700
KHBWS1005-4N7	4.7	20	250	4.77	0.13	640
KHBWS1005-5N1	5.1	23	250	4.8	0.083	800
KHBWS1005-5N6	5.6	25	250	4.8	0.083	760
KHBWS1005-6N2	6.2	25	250	4.8	0.083	760
KHBWS1005-6N6	6.6	24	250	4.8	0.08	680
KHBWS1005-6N8	6.8	24	250	4.8	0.083	680
KHBWS1005-7N3	7.3	25	250	4.8	0.1	680
KHBWS1005-7N5	7.5	25	250	4.8	0.1	680
KHBWS1005-8N2	8.2	25	250	4.4	0.1	680
KHBWS1005-8N7	8.7	25	250	4.1	0.2	480
KHBWS1005-9N0	9	25	250	4.16	0.1	680
KHBWS1005-9N1	9.1	25	250	4.16	0.1	680
KHBWS1005-9N5	9.5	24	250	4	0.2	480
KHBWS1005-10N	10	24	250	3.9	0.2	480
KHBWS1005-11N	11	26	250	3.68	0.12	640
KHBWS1005-12N	12	26	250	3.6	0.12	640



KHBWS1005-13N	13	24	250	3.45	0.21	440
KHBWS1005-15N	15	26	250	3.28	0.17	560
KHBWS1005-16N	16	25	250	3.1	0.22	560
KHBWS1005-18N	18	25	250	3.1	0.23	420
KHBWS1005-19N	19	26	250	3.04	0.2	480
KHBWS1005-20N	20	26	250	3	0.25	420
KHBWS1005-22N	22	25	250	2.8	0.3	400
KHBWS1005-23N	23	25	250	2.72	0.3	400
KHBWS1005-24N	24	25	250	2.7	0.3	400
KHBWS1005-27N	27	25	250	2.48	0.3	400
KHBWS1005-30N	30	25	250	2.35	0.35	400
KHBWS1005-33N	33	24	250	2.35	0.4	400
KHBWS1005-36N	36	25	250	2.32	0.44	320
KHBWS1005-39N	39	25	250	2.1	0.55	200
KHBWS1005-40N	40	24	250	2.24	0.65	320
KHBWS1005-43N	43	25	250	2.03	0.81	100
KHBWS1005-47N	47	25	250	2.1	0.83	150
KHBWS1005-51N	51	25	250	1.75	0.82	100
KHBWS1005-56N	56	25	250	1.76	0.97	100
KHBWS1005-58N	58	25	250	1.76	0.97	100
KHBWS1005-62N	62	25	250	1.62	1.12	100
KHBWS1005-68N	68	25	250	1.62	1.55	100
KHBWS1005-72N	72	25	250	1.26	1.55	50
KHBWS1005-75N	75	25	250	1.26	1.55	50
KHBWS1005-82N	82	25	250	1.26	1.55	50
KHBWS1005-91N	91	24	250	1.16	2	30
KHBWS1005-R10	100	24	250	1.16	2	30
KHBWS1005-R12	120	24	250	1.1	2.66	50
KHBWS1005-R15	150	24	250	1	3.5	30

\*请选用时注明公差 (F, ±1%; G, ±2%; J=±5%; K=±10%; M=±20%; N=±30%) Please specify the inductance tolerance code(F, ±1%; G, ±2%; J=±5%; K=±10%; M=±20%;N=±30%).

**KHBWS1608 Series**

Part Number	Inductance	Mini. Quality Factor	L,Q test frequency	Mini.self resonant frequency	Max.DC resistance	Max.rated Current
Unit	nH	-	MHz	MHz	Ω	mA
Symbol	L	Q	Freq.	S.R.F	DCR	Ir
KHBWS1608-1N5	1.5	24	250	12500	0.03	700
KHBWS1608-1N6	1.6	24	250	12500	0.03	700
KHBWS1608-1N8	1.8	16	250	12500	0.045	700



KHBWS1608-2N0	2	12	250	12500	0.09	700
KHBWS1608-2N2	2.2	12	100	12500	0.09	700
KHBWS1608-2N7	2.7	22	250	5900	0.045	700
KHBWS1608-3N3	3.3	22	250	5900	0.045	700
KHBWS1608-3N6	3.6	22	250	5900	0.063	700
KHBWS1608-3N9	3.9	22	250	6900	0.08	700
KHBWS1608-4N3	4.3	22	250	5900	0.063	700
KHBWS1608-4N7	4.7	20	250	5800	0.116	700
KHBWS1608-5N1	5.1	20	250	5700	0.14	700
KHBWS1608-5N6	5.6	26	250	4760	0.075	700
KHBWS1608-6N2	6.2	20	250	5700	0.14	700
KHBWS1608-6N3	6.3	20	250	5700	0.14	700
KHBWS1608-6N8	6.8	27	250	5800	0.11	700
KHBWS1608-7N5	7.5	28	250	4800	0.106	700
KHBWS1608-8N0	8	28	250	4700	0.109	700
KHBWS1608-8N2	8.2	30	250	4200	0.115	700
KHBWS1608-8N7	8.7	28	250	4600	0.109	700
KHBWS1608-9N1	9.1	28	250	5400	0.125	700
KHBWS1608-9N5	9.5	28	250	5400	0.125	700
KHBWS1608-10N	10	31	250	4800	0.13	700
KHBWS1608-11N	11	30	250	4000	0.13	700
KHBWS1608-12N	12	35	250	4000	0.13	700
KHBWS1608-13N	13	35	250	4000	0.13	700
KHBWS1608-15N	15	35	250	4000	0.17	700
KHBWS1608-16N	16	34	250	3300	0.17	700
KHBWS1608-18N	18	35	250	3100	0.17	700
KHBWS1608-20N	20	36	250	3000	0.18	700
KHBWS1608-22N	22	38	250	3000	0.19	700
KHBWS1608-23N	23	38	250	3000	0.19	700
KHBWS1608-24N	24	36	250	2650	0.135	700
KHBWS1608-27N	27	40	250	2800	0.22	600
KHBWS1608-30N	30	37	250	2250	0.22	600
KHBWS1608-33N	33	40	250	2300	0.22	600
KHBWS1608-36N	36	37	250	2080	0.25	600
KHBWS1608-39N	39	40	250	2200	0.25	600
KHBWS1608-43N	43	38	250	2000	0.28	600
KHBWS1608-47N	47	38	200	2000	0.28	600
KHBWS1608-51N	51	35	200	1900	0.27	600
KHBWS1608-56N	56	38	200	1900	0.31	600
KHBWS1608-60N	60	37	200	1800	0.33	600



KHBWS1608-62N	62	37	200	1800	0.33	600
KHBWS1608-68N	68	37	200	1700	0.34	600
KHBWS1608-72N	72	34	150	1700	0.49	400
KHBWS1608-75N	75	28	150	1700	0.52	400
KHBWS1608-82N	82	34	150	1700	0.54	400
KHBWS1608-85N	85	34	150	1700	0.58	400
KHBWS1608-91N	91	28	150	1600	0.58	400
KHBWS1608-R10	100	34	150	1400	0.58	400
KHBWS1608-R11	110	32	150	1350	0.61	300
KHBWS1608-R12	120	32	150	1300	0.65	300
KHBWS1608-R13	130	32	150	1150	0.92	290
KHBWS1608-R135	130	32	150	990	0.92	290
KHBWS1608-R15	150	28	150	990	0.92	280
KHBWS1608-R16	160	28	150	990	1.25	280
KHBWS1608-R18	180	25	100	990	1.25	240
KHBWS1608-R20	200	25	100	900	1.98	200
KHBWS1608-R215	215	25	100	900	2.1	200
KHBWS1608-R22	220	25	100	900	2.1	200
KHBWS1608-R24	240	25	100	900	2.2	200
KHBWS1608-R25	250	25	100	882	2.55	120
KHBWS1608-R27	270	26	100	830	2.8	170
KHBWS1608-R29	290	25	100	800	3.2	100
KHBWS1608-R30	300	25	100	790	3.89	100
KHBWS1608-R33	330	25	100	790	3.89	100
KHBWS1608-R39	390	25	100	780	4.35	100
KHBWS1608-R47	470	25	100	700	4.5	100

\*请选用时注明公差 (F,  $\pm 1\%$ ; G,  $\pm 2\%$ ; J= $\pm 5\%$ ; K= $\pm 10\%$ ; M= $\pm 20\%$ ; N= $\pm 30\%$ ) Please specify the inductance tolerance code(F,  $\pm 1\%$ ; G,  $\pm 2\%$ ; J= $\pm 5\%$ ; K= $\pm 10\%$ ; M= $\pm 20\%$ ;N= $\pm 30\%$ ).

### KHBWS2012 Series

Part Number	Inductance	L test frequency	Mini. Quality Factor	Mini.self resonant frequency	Max.DC resistance	Max.rated Current
Unit	nH	MHz	-	MHz	$\Omega$	mA
Symbol	L	Freq.	Q	S.R.F	DCR	Ir
KHBWS2012-2N2	2.2	250	50@1GHz	7900	0.06	800
KHBWS2012-2N7	2.7	250	50@1GHz	7900	0.06	800
KHBWS2012-2N8	2.7	250	50@1GHz	7900	0.06	800
KHBWS2012-2N9	2.9	250	50@1GHz	7900	0.06	800
KHBWS2012-3N0	3	250	50@1GHz	7900	0.06	800
KHBWS2012-3N3	3.3	250	40@1.5GHz	7900	0.08	600



KHBWS2012-3N6	3.6	250	20@1GHz	7900	0.1	200
KHBWS2012-3N9	3.9	250	20@1GHz	7900	0.11	150
KHBWS2012-4N7	4.7	250	50@1GHz	6200	0.08	600
KHBWS2012-5N1	5.1	250	50@1GHz	6200	0.08	600
KHBWS2012-5N6	5.6	250	65@1GHz	5900	0.08	600
KHBWS2012-6N2	6.2	250	65@1GHz	5900	0.08	600
KHBWS2012-6N8	6.8	250	50@1GHz	5600	0.11	600
KHBWS2012-7N5	7.5	250	50@1GHz	4800	0.14	600
KHBWS2012-8N2	8.2	250	50@1GHz	4400	0.12	600
KHBWS2012-9N1	9.1	250	60@500MHz	4300	0.1	600
KHBWS2012-10N	10	250	60@500MHz	4300	0.1	600
KHBWS2012-12N	12	250	50@500MHz	4000	0.15	600
KHBWS2012-15N	15	250	50@500MHz	3200	0.17	600
KHBWS2012-16N	16	250	50@500MHz	3200	0.17	600
KHBWS2012-18N	18	250	50@500MHz	3100	0.2	600
KHBWS2012-20N	20	250	55@500MHz	2600	0.22	500
KHBWS2012-22N	22	250	55@500MHz	2600	0.22	500
KHBWS2012-23N	23	250	50@500MHz	2400	0.22	500
KHBWS2012-24N	24	250	50@500MHz	2400	0.22	500
KHBWS2012-25N	25	250	50@500MHz	2450	0.22	500
KHBWS2012-27N	27	250	55@500MHz	2580	0.25	500
KHBWS2012-30N	30	250	55@500MHz	2400	0.25	500
KHBWS2012-33N	33	250	60@500MHz	2150	0.27	500
KHBWS2012-36N	36	250	55@500MHz	1900	0.27	500
KHBWS2012-39N	39	250	60@500MHz	1850	0.29	500
KHBWS2012-43N	43	200	60@500MHz	1800	0.34	500
KHBWS2012-47N	47	200	60@500MHz	1700	0.31	500
KHBWS2012-50N	50	200	60@500MHz	1650	0.34	500
KHBWS2012-56N	56	200	60@500MHz	1600	0.34	500
KHBWS2012-62N	62	200	60@500MHz	1450	0.36	500
KHBWS2012-64N	64	200	60@500MHz	1500	0.38	500
KHBWS2012-66N	66	200	60@500MHz	1500	0.38	500
KHBWS2012-68N	68	200	60@500MHz	1500	0.38	500
KHBWS2012-75N	78	150	60@500MHz	1400	0.4	450
KHBWS2012-78N	75	150	60@500MHz	1400	0.4	450
KHBWS2012-82N	82	150	65@500MHz	1330	0.42	400
KHBWS2012-91N	91	150	65@500MHz	1330	0.48	400
KHBWS2012-92N	92	150	65@500MHz	1330	0.48	400
KHBWS2012-R10	100	150	65@500MHz	1250	0.46	400
KHBWS2012-R11	110	150	50@250MHz	1100	0.48	400



KHBWS2012-R12	120	150	50@250MHz	1100	0.51	400
KHBWS2012-R14	140	100	50@250MHz	920	0.56	400
KHBWS2012-R15	150	100	50@250MHz	920	0.56	400
KHBWS2012-R16	160	100	50@250MHz	920	0.6	400
KHBWS2012-R18	180	100	50@250MHz	920	0.64	400
KHBWS2012-R20	200	100	50@250MHz	860	0.68	400
KHBWS2012-R215	215	100	50@250MHz	820	0.7	400
KHBWS2012-R22	220	100	50@250MHz	820	0.7	400
KHBWS2012-R24	240	100	44@250MHz	770	1	350
KHBWS2012-R25	250	100	45@250MHz	750	1.2	350
KHBWS2012-R27	270	100	48@250MHz	730	1	350
KHBWS2012-R28	280	100	48@250MHz	550	1.35	350
KHBWS2012-R29	290	150	48@250MHz	450	1.4	310
KHBWS2012-R30	300	150	48@250MHz	450	1.4	310
KHBWS2012-R33	330	100	48@250MHz	650	1.4	310
KHBWS2012-R36	360	100	48@250MHz	630	1.45	300
KHBWS2012-R39	390	100	48@250MHz	600	1.5	290
KHBWS2012-R42	420	50	33@100MHz	425	1.7	250
KHBWS2012-R43	430	50	33@100MHz	425	1.7	250
KHBWS2012-R47	470	50	33@100MHz	375	1.76	250
KHBWS2012-R56	560	25	23@50MHz	330	1.9	230
KHBWS2012-R62	620	25	23@50MHz	320	2.2	210
KHBWS2012-R68	680	25	23@50MHz	310	2.2	190
KHBWS2012-R75	750	25	23@50MHz	310	2.3	180
KHBWS2012-R82	820	25	23@50MHz	310	2.35	180
KHBWS2012-R88	880	25	23@50MHz	310	2.35	180
KHBWS2012-R91	910	25	22@50MHz	250	2.45	170
KHBWS2012-1R0	1000	25	20@50MHz	220	2.5	170
KHBWS2012-1R2	1200	25	20@25MHz	180	2.9	150
KHBWS2012-1R5	1500	25	20@25MHz	160	3.3	150
KHBWS2012-1R6	1600	25	20@25MHz	140	3.4	150
KHBWS2012-1R8	1800	25	20@25MHz	130	3.5	120
KHBWS2012-2R2	2200	25	20@25MHz	100	4.5	120
KHBWS2012-2R7	2700	25	18@25MHz	80	4.8	100
KHBWS2012-3R0	3000	25	18@25MHz	60	5	60
KHBWS2012-3R3	3300	25	18@25MHz	50	6.8	50
KHBWS2012-4R7	4700	25	18@25MHz	40	7	30

\*请选用时注明公差 (F,  $\pm 1\%$ ; G,  $\pm 2\%$ ; J= $\pm 5\%$ ; K= $\pm 10\%$ ; M= $\pm 20\%$ ; N= $\pm 30\%$ ) Please specify the inductance tolerance code(F,  $\pm 1\%$ ; G,  $\pm 2\%$ ; J= $\pm 5\%$ ; K= $\pm 10\%$ ; M= $\pm 20\%$ ;N= $\pm 30\%$ ).